

AC55

TRU-WAVE™

Rotary Phase Converter Data Sheet



TRUE History... Engineering Power Since 1968

TRUE Quality... Backed by a 10 YEAR Warranty

TRUE Power... Pure Smooth AC Waveform

TEMCo Introduces... TRU-WAVE™

Engineered to meet the requirements of the most demanding and sensitive of industrial three phase machines, TEMCo's TRU-WAVE™ technology is a signature feature found only on TEMCo phase converters.

TEMCo's TRU-WAVE™ Phase Converter produces a three phase sinusoidal waveform, generated from a single phase source, offset at 120°.

By implementing precision rotor/winding tuning along with TEMCo's Exclusive Power State Control™, TRU-WAVE™ produces a pure sinusoidal output with optimal phase balance free of harmonic distortion, and other damaging transients.

TEMCo's TRU-WAVE™ - Power quality built on a reputation you can Trust.

TEMCo TRU-WAVE™ Features

 <i>Supporting Your Economy</i> American Made	CNC ready	POWER QUALITY Designed for Precision Power and CNC Machinery	 <i>Quietest in Class Operation</i> TEMCo ULTRA Whisper™ Ultra High Carbon Cast Steel Chassis
 <i>Energy Efficient</i> Environmentally Friendly 100% Copper Windings		<i>International Standard</i> 208-240v 60Hz, 380-415v 50Hz, 440-480v 60Hz	10 <i>Set it and Forget It</i> Industry's Only 10 Year Warranty

rev 1.0

Corporate Headquarters: TEMCo – Tower Electric Motor Company 41474 Christy St. Fremont CA 94538 USA
Inside USA (800) 613-2290 International (510) 490-2187 Fax (510) 490-1507 www.temcophaseconverter.com

All specifications subject to change without notice.

AC55

TRU-WAVE™

Rotary Phase Converter Data Sheet



Designed for CNC First - not as an after thought.

TEMCo was one of the first to provide a single to three phase power conversion solution for CNC Equipment users. In fact, TEMCo is the only company to offer a 100% Satisfaction Guarantee* backing the TRU-WAVE Phase Converter Line for the operation of ANY CNC machine!



International Standard 50 Hz and 60 Hz operation with full capacity.

Never requires a De-Rate for operation on 50 Hz. Additionally all units are field re-configurable for 208-240 (60Hz), 380-415(50Hz), 440-480 (60Hz)

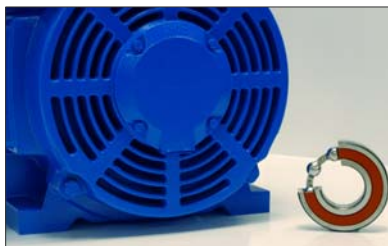

“Make Your Money Work for You – not Against You”

Why purchase a solution with a limited lifespan requiring heavy maintenance? The TEMCo TRU-WAVE™ Phase Converter line has been engineered to eliminate the cost of long term maintenance.

Of course none of this means anything without a guarantee... **It comes with a 10 Year Warranty – “Now that’s Quality”**



“Unique Design Approach to Connections”

TEMCo uses the simplest and fastest connections systems in the industry. TEMCo Advantages include: Extra Large connections compartment will provide your electrician with ample room for cabling. Oversized connection lugs come pre-installed saving installation hardware cost.

Save time during installation through clearly marked, committed connections points for your single phase input, three phase output and grounding connections. Just insert each wire and tighten it down; “it’s that simple”.

rev 1.0

Corporate Headquarters: TEMCo – Tower Electric Motor Company 41474 Christy St. Fremont CA 94538 USA
Inside USA (800) 613-2290 International (510) 490-2187 Fax (510) 490-1507 www.temcophaseconverter.com

All specifications subject to change without notice.

Rotary Phase Converter Data Sheet

Common TRU-WAVE™ Phase Converter Applications:

- CNC Machine Shops
- Cabinet Builders/Woodworking
- Farm Equipment
- Restaurant Equipment
- Petrochemicals/Processing
- Home Hobbyist/Home Business
- Oil Fields
- Irrigation/Pump Stations
- High Tech/Robotics/Lasers
- Military
- Aerospace
- Medical/ Hospital



TEMCo Opto-Sense™ 80 Point Quality Inspection System.

A multitude of tests such as fastener torque check, vibration band analysis, full spec electrical and more are performed on every unit prior to being released from manufacturing.



“Rugged Quality right down to the Packaging”

The highest quality products demand an equal match in the containers used for their transportation. You can't risk time lost due to freight damage. TEMCo takes it the extra mile with rugged heavy duty wood crating for every unit, models AC21 and larger. Some manufacturers use a cardboard box on a pallet. At TEMCo, it's these fine details that complete a world class solution.

The sky is the limit with TEMCo's TRU-WAVE™. With its versatility it can power any type of three phase machinery, ranging from Miller welders and Hobart mixers, to Hurco machining centers and Yamaha robotics. TEMCo is on the forefront of phase converter technology and continues to innovate and provide products that produce superior quality power. *When you demand the best, demand TEMCo.*

rev 1.0

Corporate Headquarters: TEMCo – Tower Electric Motor Company 41474 Christy St. Fremont CA 94538 USA
Inside USA (800) 613-2290 International (510) 490-2187 Fax (510) 490-1507 www.temcophaseconverter.com

All specifications subject to change without notice.

TRU-WAVE™ Phase Converter Specifications – Model AC55

1-phase input voltage	230v/400v/460 (max deviation ±10%)
1-phase input frequency	50/60Hz
3-phase output voltage	= Input voltage + 5% on T2 (non-loaded)
3-phase output frequency	same as input
3-phase output voltage tolerance	± 5%
3-phase output phase angle	120°
Temperature rating	40° C Ambient
Ambient humidity	<95% (non-condensing)
Maximum altitude (de-rate .004% for each foot above 3300ft)	3300 ft above sea level
Enclosure	NEMA 1 use kit p/n ACR5 for 3R rating
Recommended for All General Electrical Loads	YES
Recommended for All CNC and Electronic Loads	YES
Required RVI Mounting Isolator	RVI524
Recommended Magnetic Starter	MAG55

	230v (60 Hz only)	400v (50 Hz only)	460v (60 Hz only)
Output Configuration	DELTA	DELTA	DELTA
CNC & ELECTRONIC LOADS			
Continuous kW output	27 kW		
Continuous 3-phase Amp output	86 A	49 A	43 A
RESISTIVE ELECTRICAL LOADS			
Continuous kW output	41 kW		
Continuous 3-phase Amp output	128 A	74 A	64 A
INDUCTIVE ELECTRICAL LOADS			
Continuous kW output	35 kW		
Continuous 3-phase Amp output	111 A	64 A	56 A
MOTOR LOADS			
Maximum Easy run or start HP	50 HP		
Maximum Medium run or start HP	38 HP		
Maximum Hard run or start HP	25 HP		
Maximum group load HP	56 HP		
RLA 1-phase input	calculated based on three phase load x 1.732		
Approx. 1-phase idle amps	19	11	10
MCA 1-phase	148 A	85 A	74 A
Min 1-phase fuse	150 A	90 A	75 A
MOP 1-phase	225 A	125 A	110 A
Recommended 1-phase wire size *(1)	4/0	2 AWG	4 AWG
Recommended 3-phase wire size *(1)	Based on load requirement		
Electrical connection wire range	2 connections per lug, 6 AWG -kCMIL, including ground		

RLA – Rated Load Amps

MCA – Minimum Circuit Amps

MOP – Maximum Overcurrent Protection

rev 1.0

Corporate Headquarters: *TEMCo* – Tower Electric Motor Company 41474 Christy St. Fremont CA 94538 USA
 Inside USA (800) 613-2290 International (510) 490-2187 Fax (510) 490-1507 www.temcophaseconverter.com

AC55

TRU-WAVE™

Rotary Phase Converter Data Sheet

Dimensions:

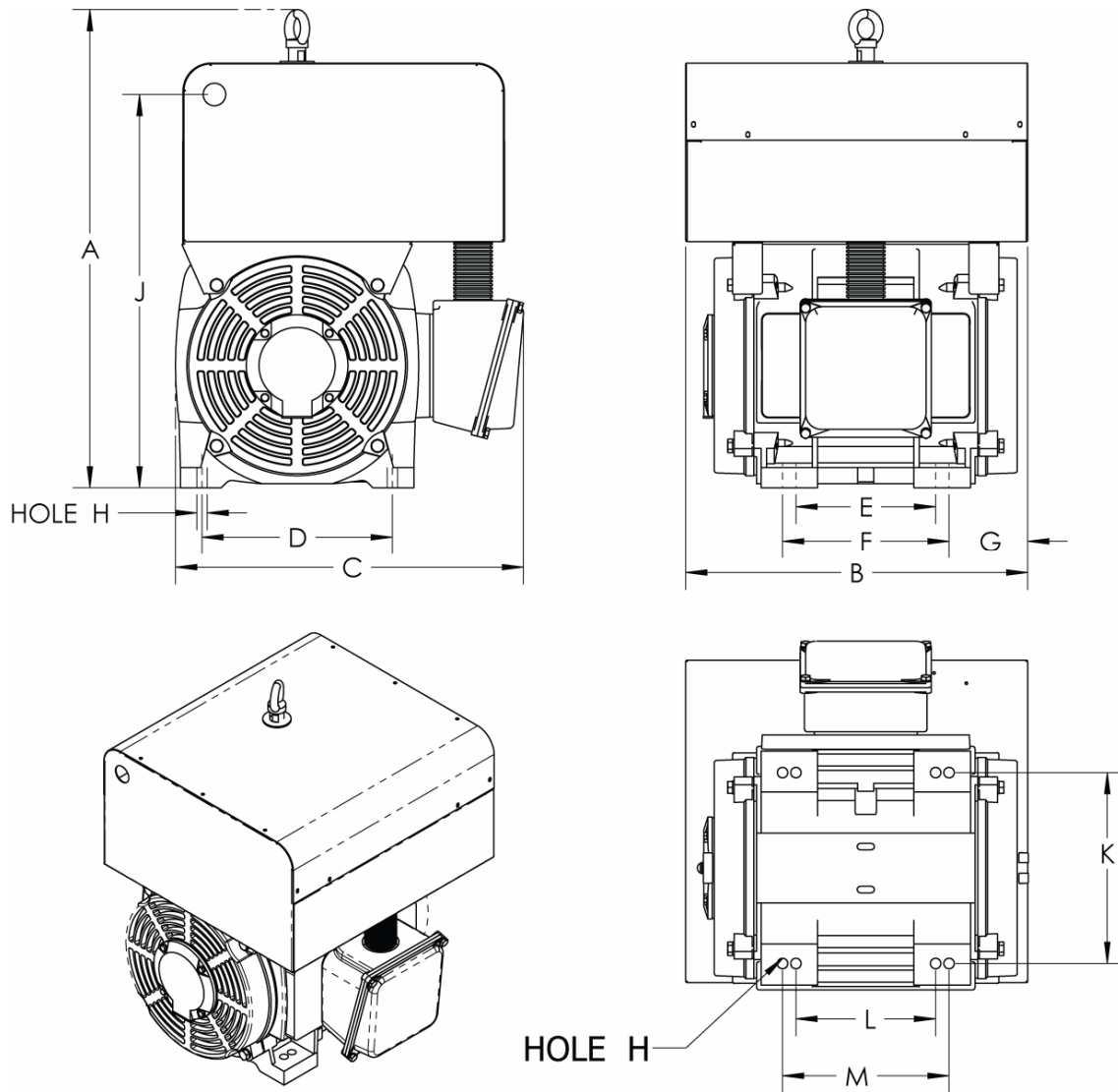

All dimensions given in inches

Model	A	B	C	D	E	F	G	H	J	K	L	M	Ship Dim	Ship Wt
AC21	30.3	23.63	19.5	11		11	5.5	0.53	25.15	11		11	34Lx32Wx43T	594 lbs
AC29	32	24.75	20.38	12.5		10.5	5.69	0.66	26.65	12.5		10.5	34Lx32Wx43T	724 lbs
AC36	32	25.75	20.38	12.5		12	5.19	0.66	26.65	12.5		12	34Lx32Wx43T	754 lbs
AC44	35.25	26.5	25.63	14	10.25	12.25	5.88	0.77	29	14	10.25	12.25	34Lx32Wx43T	994 lbs
AC55	35.25	26.5	25.63	14	10.25	12.25	5.88	0.77	29	14	10.25	12.25	34Lx32Wx43T	1014 lbs

rev 1.0

Corporate Headquarters: *TEMCo* – Tower Electric Motor Company 41474 Christy St. Fremont CA 94538 USA
 Inside USA (800) 613-2290 International (510) 490-2187 Fax (510) 490-1507 www.temcophaseconverter.com

Single Unit Operation Electrical Connection Diagram:

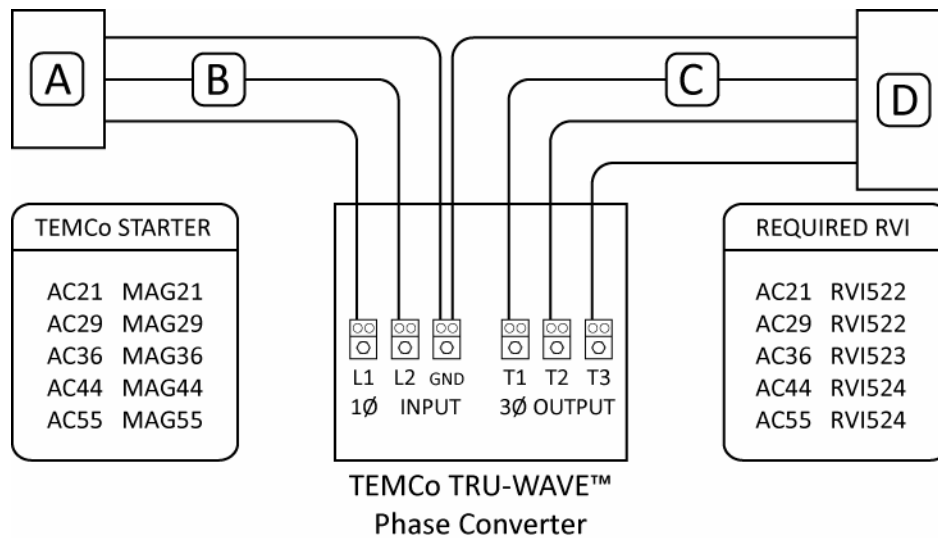

- A** Single Phase TEMCo MAG Starter or Fused Disconnect: Refer to technical specifications for sizing. For optimal protection, device setting(s) should be based on minimum requirements of three phase load converted to single phase (3 –phase load amps x 1.732) but not lower than recommendation in technical specifications.
 - B** Single phase supply conductors should be based on circuit protection rating as required by NEC.
 - C** Three phase output conductors should be based on circuit protection rating as required by NEC and the requirement of the three phase load equipment.
 - D** Three phase TEMCo MAG Starter, Fused Disconnect or Circuit Breaker. Refer to three phase load equipment specifications for sizing details.
- For Multiple Unit Operation:**
- E** Single Phase Input Buss: Each unit should be brought on-line separately to reduce system start up current and it's affect on the single phase line. Verify that all units wiring corresponds with one another. L1 connected to L1 etc.
 - F** Three Phase Output Buss: Verify that all units wiring corresponds with one another. T2 connected to T2 etc.

Multiple Unit Operation Electrical Connection Diagram:

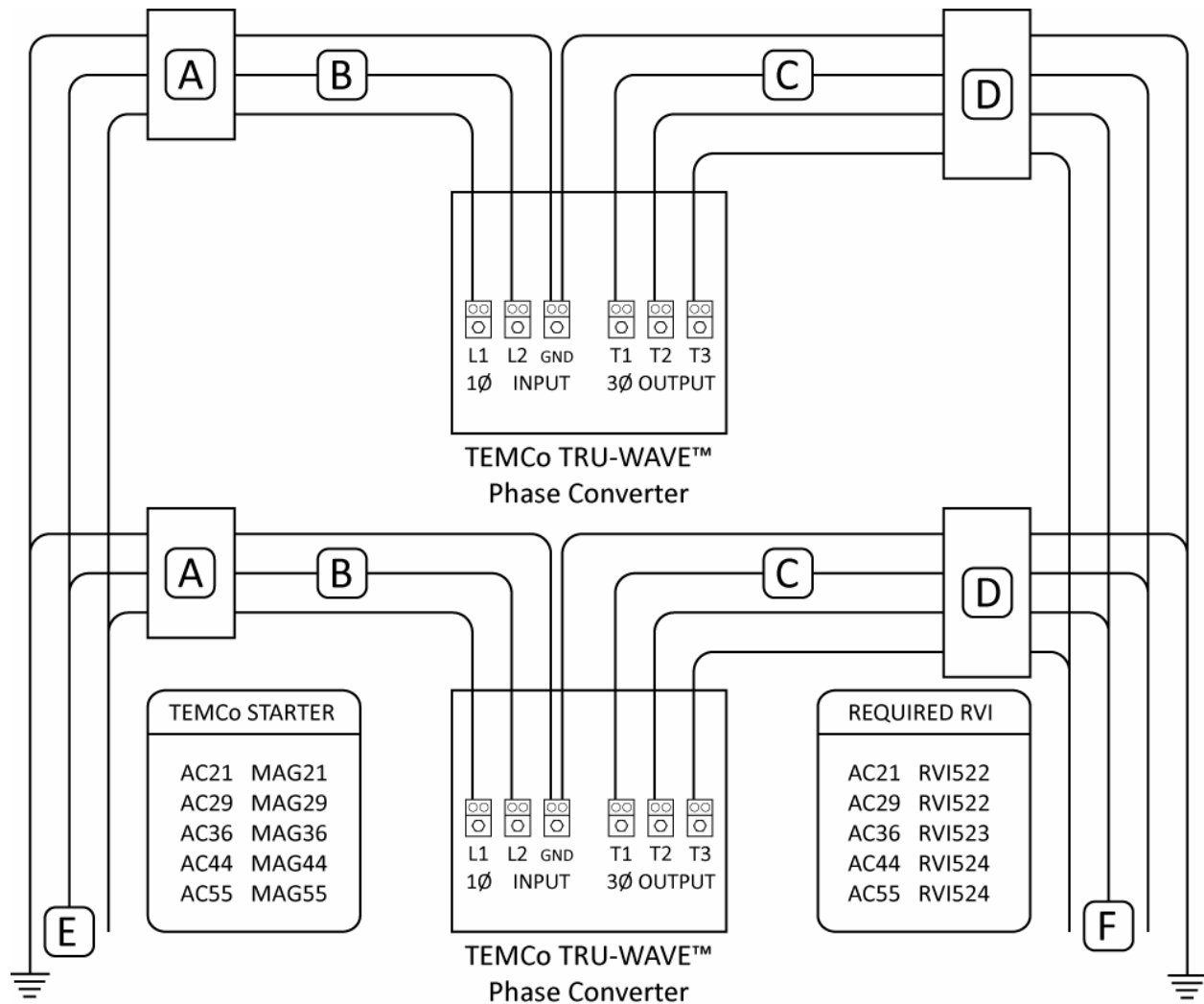

Installation Notes:

1. These diagrams are not intended to replace or supersede any requirements of local, state or national electrical codes.
2. Use only protective dual element time delay fuses or a magnetic starter with thermal overloads that carry an amperage rating within the limits set by the technical specifications.
3. Do not bolt the TEMCo Phase Converter directly to the floor. Solid mounting can cause a reduction in life expectancy of the rotating assembly, loosening of connections and hardware, and will amplify noise levels. TEMCo offers engineered Resilient Vibration Isolators for this purpose.
4. No load voltage on the three phase output from T1 – T2 or T3 – T2 will exceed T1 – T3 by 5% (T2 on the output is the generated line). Voltages will balance when a load is applied.
5. Do not connect control circuits which require ground or neutral to the generated line T2 on the three phase output. This TEMCo Phase Converter provides a three phase *DELTA* output. On the output, voltage from T2 (generated line) to ground/neutral will be 180-220V on a 208-240V system. If a *WYE* (or 4 wire) three phase output is required, a three phase *DELTA* to *WYE* transformer is required. Please consult your TEMCo sales representative for the supply of this type of transformer.
6. This TEMCo Phase Converter must always be started before any load is applied. Loads include non-loaded three phase transformers which constitute a small inductive load.
7. All loads must be turned off in the event of a power failure to prevent the TEMCo Phase Converter from being restarted under load when the power comes back on. Equipping three phase loads with magnetic starters is recommended. A magnetic starter will automatically shut off equipment if power is lost, thus protecting the TEMCo Phase Converter from starting under load when power is restored.
8. As many TEMCo TRU-WAVE™ Phase Converters as are needed to suit your application may be connected in parallel for increased output provided that your single phase branch circuit is capable of supporting the load. It is recommended that each unit be started independently to reduce single phase supply line loading during TEMCo Phase Converter start up.